

SECTION 'A'

TOP VIEW

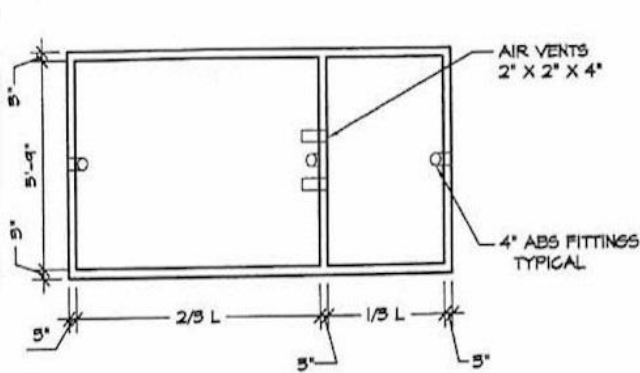

LID TYP., SEE DETAIL BELOW

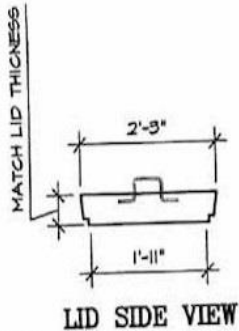

Capacity	Height	Width	Length	Outlet
500	4'-3"	3'-7"	8'-7"	
810	5'-8"	4'-1"	8'-8"	53"
1200	5'-10"	5'-2"	9'-3"	55"
1500	5'-8"	6'-3"	9'-6"	53"
2000	5'-8"	6'-3"	12'-6"	53"

NOTES:

1. Tank cover limits the depth of soil on the cover to be Minimum 1'6" and Maximum 4'6"
2. All concrete shall develop a minimum compressive strength of 4000 psi at 28 days or sooner. Concrete shall have a maximum water ratio of 0.45.
3. Cement to be Portland conforming to ASTM C 150. Reinforcing steel shall be intermediate grade, deformed, conforming to ASTM A-616 Grade 40.
4. Reinforcing bars shall be in as long lengths as practicable and shall be lapped a minimum of 15 inches, or 40 bars diameters.
5. All tanks specified as "in & out" by Selvage Concrete Products, Inc. shall be coated on the entire interior and exterior area with an approved damproof and waterproof compound complying with ASTM D 41-78 or better. Coatings shall be applied per the manufacturer's recommendations and shall be environmentally friendly as per EPA regulation 40CFR261.4
6. Fill tank with water after it has been set in placed and backfilled as per manufacturer's recommendation.

## H2O TRAFFIC RATED TANKS

Sealed "In & Out"



*RE Kent* 5/19/03

SELVAGE CONCRETE PRODUCTS, INC.  
 3309 SEBASTOPOL ROAD  
 SANTA ROSA, CA 95407  
 PHONE 707-542-2762