

Section A

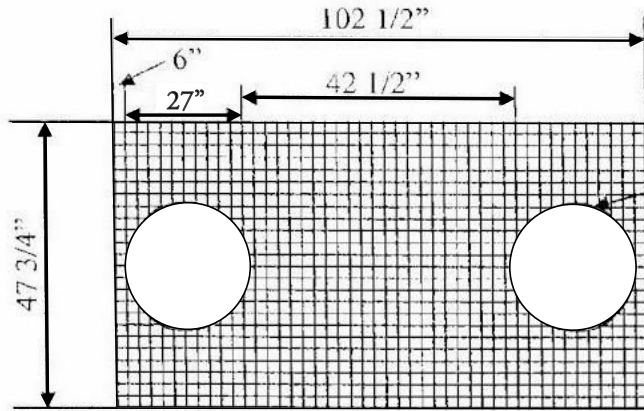

TOP VIEW SECTION B

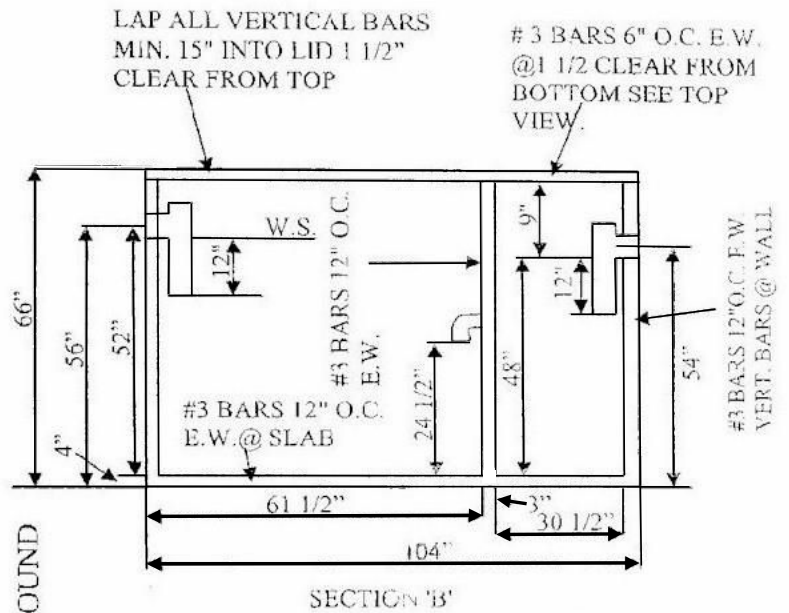

SECTION 'B'

NOTES:

1. All concrete shall develop a minimum compressive strength of 4000 psi at 28 days or sooner. Concrete shall have a maximum water ratio of 0.45.
2. Cement to be Portland conforming to ASTM C 150. Reinforcing steel shall be intermediate grade, deformed, conforming to ASTM A-616 Grade 40.
3. Reinforcing bars shall be in as long lengths as practicable and shall be lapped a minimum of 15 inches, or 40 bars diameters.
4. Welded wire shall conform to ASTM designation A 185, Lap Fabric at slices a minimum of 6 inches.
5. All tanks shall be coated on the interior extending to a minimum of four (4) inches below the water line, and shall cover all of the internal area above that point with an approved damproof and waterproof compound complying with ASTM D 41-78 or better. Coatings shall be applied per the manufacturer's recommendations and shall be environmental friendly as per EPA regulation 40CFR261.4
6. Tank shall bear on undisturbed soil a minimum of 18 inches below original grade on a solid bed and to be installed level.
7. Soil bearing capacity shall be a minimum of 1000 psi.
8. Fill tank with water after it has been set in placed and backfilled as per manufacturer's recommendation.
9. Do not install none H2O rated tanks in a traffic area.
10. The design of this tank is based on an equivalent fluid pressure of 30 psi.
11. Design Capacity: 810 gallons.

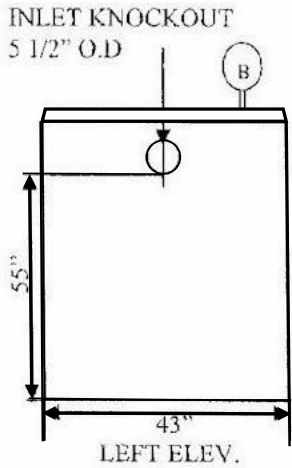

LEFT ELEV.

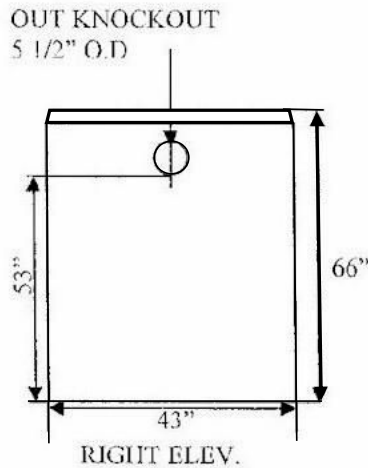

RIGHT ELEV.

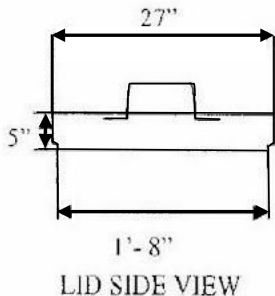

LID SIDE VIEW

Tank coverage design limits the depth: 6 inches minimum, 4 feet maximum

Gallons per inch = 16.53

SELVAGE CONCRETE PRODUCTS, INC.
 3309 SEBASTOPOL ROAD
 SANTA ROSA, CA 95407
 PHONE 707-542-2762

810 GALLONS SEPTIC TANK



RE Kent 5/12/03